

CODICE Code Code Code	TIPO Type Type Typ	GRAND. Size Grand. Grösse	CARATTERISTICHE MECCANICHE Mechanical Features/Caractéristiques Mécaniques/Mechanische Daten								CARATTERISTICHE ELETTRICHE Electrical Features/Caractéristiques Electriques/Elektrische Daten					
			MOMENTO STATICO Static Moment Moment Statique Statisches Moment		FORZA CENTRIFUGA Centrifugal Force Force Centrifuge Fliehkraft				PESO Weight Poids Gewicht		POTENZA MAX Input Power Puissance Max Max. Leistung		CORR. NOM. Nom. Current Courant Nom. Nennstrom		RAPP. IA/IN Is/In Ratio Rapp. Ia/In Ia/In Ratio	
			(kgmm)		kg		kN		(kg)		(W)		(A)			
			50Hz	60Hz	1000rpm 50Hz	1200rpm 60Hz	1000rpm 50Hz	1200rpm 60Hz	50Hz	60Hz	50 Hz	60Hz	400V 50Hz	460V 60Hz	50Hz	60Hz
BS10-0004	BM 40/10	01	31	31	35	50	0,34	0,49	5,8	5,8	85	90	0,35	0,35	1,5	1,6
BS10-0006	BM 65/10	02-A	46,2	46,2	52	74	0,51	0,73	9,2	9,2	140	160	0,66	0,66	1,55	1,8
BS10-0011	BM 110/10	02-A	82,1	82,1	92	132	0,90	1,29	10,9	10,9	140	160	0,66	0,66	1,55	1,8
BS10-0020	BM 200/10	03	160,6	160,6	180	259	1,77	2,54	24,5	24,5	240	280	0,53	0,54	2,4	2,6
BS10-0027	BM 270/10	03	199	199	222	320	2,18	3,14	25,9	25,9	260	300	0,55	0,56	2,4	2,6
BS10-0039	BM 390/10	04-A	282	282	315	454	3,09	4,45	34,5	34,5	320	350	0,70	0,68	2,85	3,0
BS10-0049	BM 490/10	04-A	437	355	489	572	4,80	5,61	40,6	38	450	520	0,95	0,95	3,05	3,3
BS10-0053	BM 530/10	04-B	437	355	489	572	4,80	5,61	40,7	38,1	450	520	0,95	0,95	3,05	3,3
BS10-0063	BM 630/10	04-A	567	---	634	---	6,22	---	44,7	---	500	---	1,0	---	2,9	---
BS10-0065	BM 650/10	04-B	567	437	634	703	6,22	6,90	44,8	41,4	500	520	1,0	0,95	2,9	3,3
BM10-0100	BM 1000/10	15-A	826	577	923	929	9,05	9,11	57	53	720	800	1,4	1,3	3,0	3,1
BM10-0130	BM 1300/10	15-A	1208	826	1350	1330	13,24	13,05	70	63	800	900	1,6	1,6	3,4	4,0
BM10-0150	BM 1500/10	15-A	1328	1017	1484	1637	14,56	16,06	75	68	1050	1000	2,2	2,2	3,8	4,0
BM10-0160	BM 1600/10	20	1356	1082	1516	1742	14,87	17,09	90	85	1200	1400	2,3	2,3	4,5	4,8
BM10-0200	BM 2000/10	20	1629	1237	1820	1992	17,85	19,54	95	86	1200	1400	2,3	2,3	4,5	4,8
BM10-0230	BM 2300/10	20	2007	1629	2243	2345	22,00	23,00	108	97	1250	1400	2,4	2,3	4,3	4,8
BM10-0300	BM 3000/10	30	2594	2030	2900	3268	28,45	32,06	138	131	2000	2100	4,4	4,2	4,8	5,15
BM10-0500	BM 5000/10	50	4088	3115	4570	5015	44,83	49,20	192	181	2600	3000	5,0	5,0	5,95	5,95
BM10-0520	BM 5200/10	50	4452	---	4977	---	48,82	---	192	---	3000	---	6,0	---	6,0	---
BM10-0700	BM 7000/10	70-A	6240	4088	6976	6582	68,43	64,57	274	250	5500	6000	9,5	9,5	5,1	5,3
BM10-0850	BM 8500/10	70-B	7650	5280	8550	8500	83,88	83,39	317	289	8000	8500	14,4	13,0	4,3	4,8
BM10-1000	BM 10000/10	120-B	8651	5908	9671	9512	94,87	93,31	395	370	8500	8800	15,0	14,3	4,5	4,7
BM10-1200	BM 12000/10	120-C	10748	7650	12015	12315	117,87	120,81	414	388	9800	10800	17,0	16,7	5,4	5,5
BM10-1350	BM 13500/10	120-C	12015	*****	13431	*****	131,76	---	430	****	10000	*****	17,2	*****	5,3	***
BM10-1500	BM 15000/10	150-A	13420	9006	15000	14500	147,15	142,25	650	610	11500	12000	20,5	18,6	5,9	5,8
BM10-1800	BM 18000/10	150-B	16102	10559	18000	17000	176,58	166,77	710	660	13000	14000	23,2	21,7	5,7	6,0
BM10-2000	BM 20000/10	150-B	18000	11950	21222	19235	208,19	188,70	740	690	14500	15000	24,9	22,5	5,9	5,8
BM10-2300	BM 23000/10	200	20593	12485	23021	20101	225,84	197,19	920	890	18700	20000	30,1	28,4	4,7	5,2

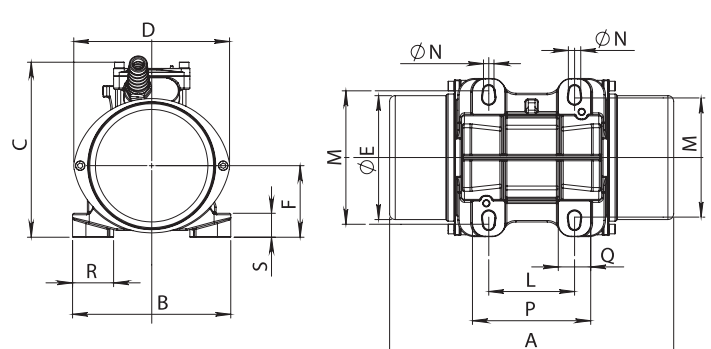

TIPO Type Type Typ	GRAND. Size Grand. Grösse	DIMENSIONI D'INGOMBRO Overall dimensions Cotes dimensions Abmessungen (mm)									DIMENSIONI DI FISSAGGIO Fixing dimensions Cotes pour le fixage Abmessungen zur Befestigung (mm)							PRESSACAPO Cable gland Presse étoupe Kabelverschraub.	
		RIF.	A	B	C	D	Ø E	F	G	L	M	VITI SCREWS Ø N	P	Q	R	S	ALIMENT. POWER	TERMIST. THERMIST.	
BM 40/10	01-A	2	230	150	145	130	105	60	55	62÷74 70	106 130	4 x M8	99	30	35	10	M16x1,5	-----	
BM 65/10	02-A	3	260	166	185	160	130	75	50	90 90	125 140	4 x M12 4 x M10	120	30	40	12	M20x1,5	-----	
BM 110/10	02-A	3	298	166	185	160	130	75	69	90 90	125 140	4 x M12 4 x M10	120	30	40	12	M20x1,5	-----	
BM 200/10	03	4-a	350	190	205	187	151	85	85	100	160	4 x M12	136	33	40	16	M20x1,5	-----	
BM 270/10	03	4-a	350	190	205	187	151	85	85	100	160	4 x M12	136	33	40	16	M20x1,5	-----	
BM 390/10	04-A	4-a	355	210	236	216	181	101	71	120	170	4 x M16	160	40	43	20	M20x1,5	-----	
BM 490/10	04-A	4-a	415	210	236	216	181	101	101	120	170	4 x M16	160	40	43	20	M20x1,5	-----	
BM 530/10	04-B	4-a	415	210	236	216	181	101	101	120	170	4 x M16	160	40	43	20	M20x1,5	-----	
BM 630/10	04-A	4-a	453	210	236	216	181	101	120	120	170	4 x M16	160	40	43	20	M20x1,5	-----	
BM 650/10	04-B	4-a	453	210	236	216	181	101	120	120	170	4 x M16	160	40	43	20	M20x1,5	-----	
BM 1000/10	15-A	4-a	488	245	260	258	219	122	107	140	190	4 x M16	190	40	45	25	M20x1,5	-----	
BM 1300/10	15-A	4-a	544	245	260	258	219	122	135	140	190	4 x M16	190	40	45	25	M20x1,5	-----	
BM 1500/10	15-A	4-a	572	245	260	258	219	122	149	140	190	4 x M16	190	40	45	25	M20x1,5	-----	
BM 1600/10	20	4-a	580	275	283	278	239	132	136	155	225	4 x M20	205	50	55	30	M20x1,5	-----	
BM 2000/10	20	4-a	580	275	283	278	239	132	136	155	225	4 x M20	205	50	55	30	M20x1,5	-----	
BM 2300/10	20	4-a	635	275	283	278	239	132	159	155	225	4 x M20	205	50	55	30	M20x1,5	-----	
BM 3000/10	30	4-a	610	325	344	325	283	157	137	155	255	4 x M22	220	55	60	35	M25x1,5	-----	
BM 5000/10	50	4-a	697	340	374	355	309	172	160	180	280	4 x M24	240	60	65	40	M25x1,5	M20x1,5	
BM 5200/10	50	4-a	697	340	374	355	309	172	160	180	280	4 x M24	240	60	65	40	M25x1,5	M20x1,5	
BM 7000/10	70-A	4-a	782	392	415	398	347	191	177	200	320	4 x M27	305	87	78	45	M25x1,5	M20x1,5	
BM 8500/10	70-B	4-a	846	392	415	398	347	191	202	200	320	4 x M27	305	87	78	45	M25x1,5	M20x1,5	
BM 10000/10	120-B	4-b	864	455	448	460	411	225	197	130	375	6 x M30	340	86	83	50	M25x1,5	M20x1,5	
BM 12000/10	120-C	4-b	900	455	448	460	411	225	197	130	375	6 x M30	340	86	83	50	M25x1,5	M20x1,5	
BM 13500/10	120-C	4-b	900	455	448	460	411	225	197	130	375	6 x M30	340	86	83	50	M25x1,5	M20x1,5	
BM 15000/10	150-A	4-c	951	575	550	545	497	270	168	140	480	8 x M42	520	90	100	45	M40x1,5	M20x1,5	
BM 18000/10	150-B	4-c	951	575	550	545	497	270	168	140	480	8 x M42	520	90	100	45	M40x1,5	M20x1,5	
BM 20000/10	150-B	4-c	951	575	550	545	497	270	168	140	480	8 x M42	520	90	100	45	M40x1,5	M20x1,5	
BM 23000/10	200	4-c	990	615	600	595	541	300	168	140	520	8 x M42	545	90	100	50	M40x1,5	M20x1,5	

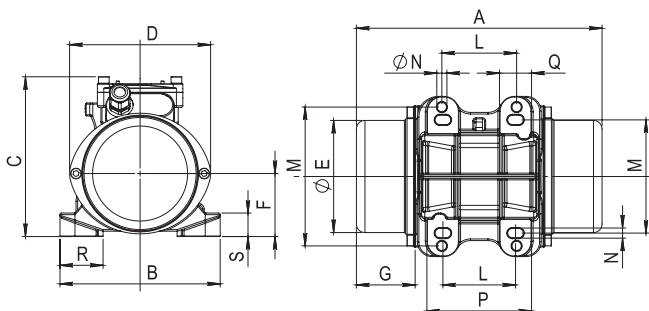
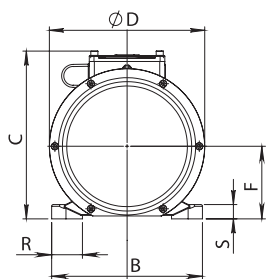

RIF. 4 a/b/c

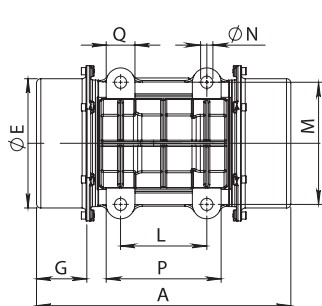

RIF. 4 a

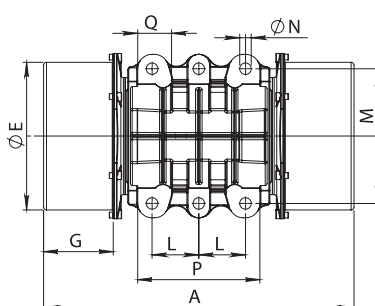

RIF. 4 b

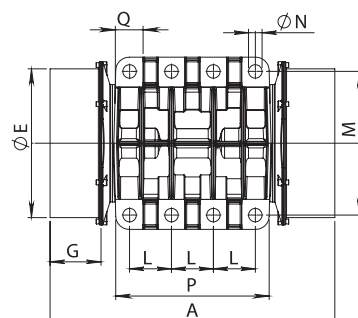

RIF. 4 c